

Bracket Assy.	None
Bolt Packages:	
Bracket	711600 (Inc. items 8-12, 23, 24)
Pulley	None
Idler	None
Tensioner	None

Make	Chevy/GMC C4500
Engine	6.6L
Fuel	Diesel
Year	2004-
Equipment	Turbo, with A/C
Revised	NC 3-8-04

Item	Part No.	Description
1.	715008	Engine bracket
2.	711216	Pump mount bracket
3.	740144	Clutch
4.	711596	Harness bracket
5.	745001	Crank pulley assy.
6.	711484	Flat washer, 2.00" x .188"
7.	*	Pump
8.	110425	3/8-16 x 1 1/4 Bolt
9.	110676	3/8 Flat washer
10.	110672	3/8 Lock washer
11.	110113	M10 x 1.5 x 90 Bolt
12.	110489	M10 x 1.5 x 95 Bolt
13.	OEM	Bolt
14.	740289	Tensioner
15.	740294	Idler pulley
16.	110250	3/8-16 x 2 1/2 Socket head bolt
17.	110707	M10 x 1.5 x 25 LH Bolt
18.	OEM	Bolt
19.	711486	1/2-13 x 3/4 socket head bolt w/.665" dia. head
20.	720242	Hose, trans. cooler 45"
21.	720243	Hose, trans. cooler 26"
22.	742008	Belt, Micro-V K060594
23.	110422	5/16-18 x 3/4 Bolt
24.	110608	5/16-18 Nut

**FIG. 1**  
**BELT DIAGRAM**

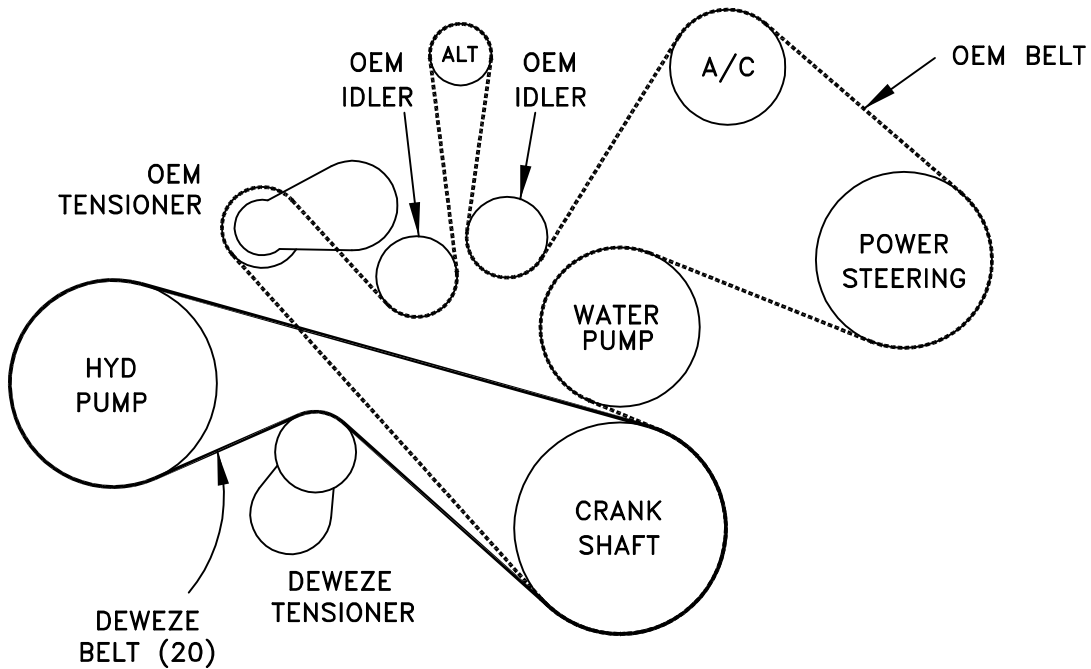

FIG. 2

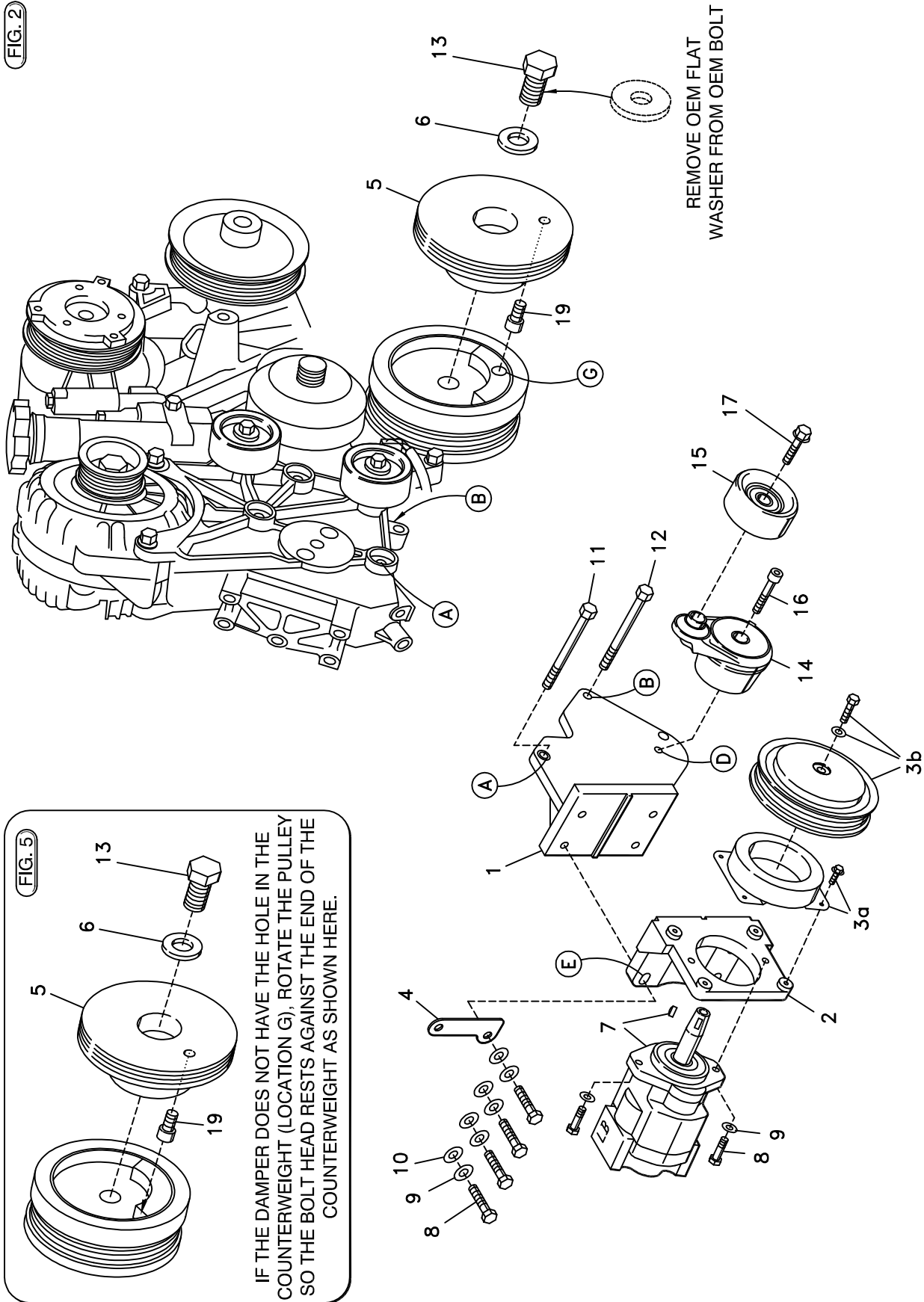
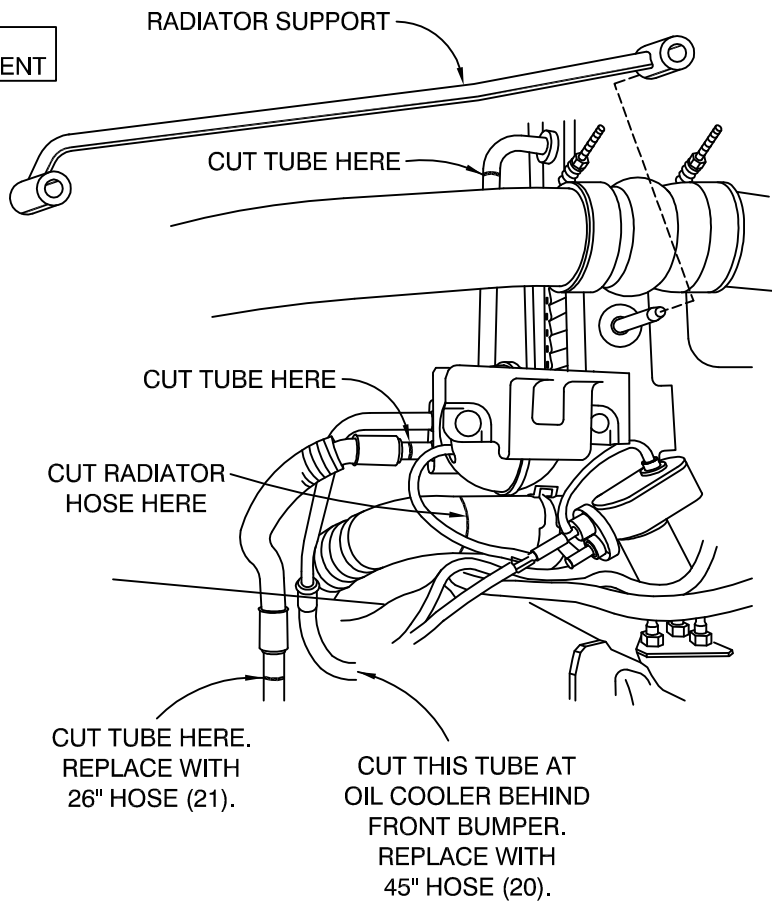

FIG. 5

IF THE DAMPER DOES NOT HAVE THE HOLE IN THE COUNTERWEIGHT (LOCATION G), ROTATE THE PULLEY SO THE BOLT HEAD RESTS AGAINST THE END OF THE COUNTERWEIGHT AS SHOWN HERE.

**FIG. 3**

**TRANSMISSION COOLER TUBE  
MODIFICATION AND REPLACEMENT**



**FIG. 4**

**REAR BRACKET MOUNTING  
AND WIRING RELOCATION**

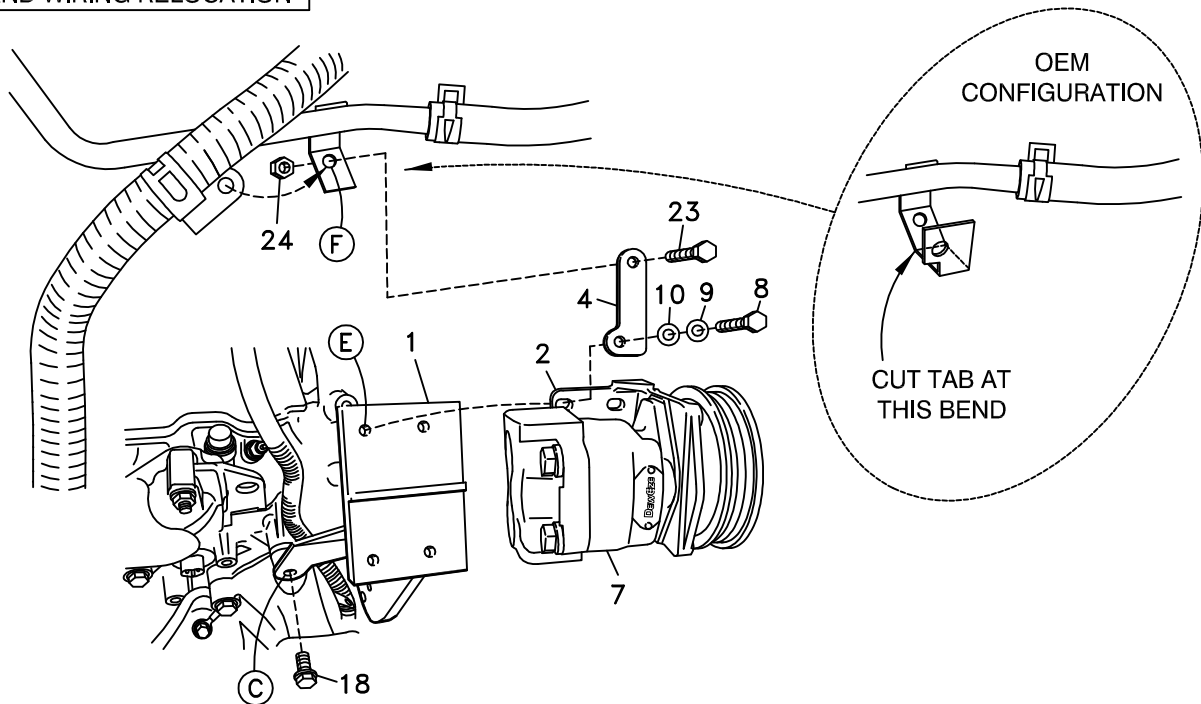

# DewEze

## Clutch Pump Kit

Kit # 700425  
CHEVY/GMC 6.6L  
C5500, C6500

2004-

## INSTALLATION INSTRUCTIONS

---

1. Disconnect the battery.
2. Drain the coolant from the radiator. While the coolant is draining, remove the top half of the fan shroud. This will allow access to the fan so it can be removed.
3. After the fan is removed, remove the starter. Stick a 3/4" rod into the flywheel so it cannot turn. Remove the OEM bolt (13) and large flat washer from the center of the crankshaft balancer. The OEM flat washer will not be used over. If the 1/2 x 3/4 socket head bolt (19) is not in the back side (the side with the hub) of the DewEze crank pulley (5), thread it in. Mount the pulley placing the socket head bolt into the hole in the damper counterweight (Location G, Fig. 2). If the damper does not have the hole in the counterweight, rotate the pulley counterclockwise so the socket head bolt rests against the end of the counterweight (Fig. 5). Fasten the pulley with the OEM bolt (13) and the DewEze flat washer (6). Torque the bolt to 260 lb-ft. Replace the starter.
4. Remove the lower hose where it is connected to the radiator. Cut the straight section of the hose off at where the hose begins to bend (See Fig. 3). Reconnect the hose and clamp it. This is for clearance to get the hose away from the clutch pulley and belt.
5. Remove the radiator support rod to better access the engine where the pump mounts (Fig. 3).
6. Unbolt the wiring harness from the tab on the heater hose line. Unbolt that line from the engine. Cut the leg off of the tab as shown in Fig. 4.
7. Refer to Fig. 3 for the following: The transmission cooling lines will be in the way of the clutch pulley and need to be relocated. Cut and remove the two transmission lines at the places shown. Follow the one line to the oil cooler behind the front bumper. Cut this line at the cooler. Replace this line with the 45" hose (20). Replace the other hose with the 26" hose (21). The lower steel line that this hose attaches to will need to be bent in about 40° so the hose will clear the clutch pulley. Use a 5/8" tubing bender.
8. Remove the OEM bolts from Locations A and C. Push the wiring cables back against the engine so they will clear the bracket when it is bolted on (Fig. 4).
9. Bolt the pump (7) to the footmount bracket (2) with two 3/8 x 1 1/4 bolts (8) and two 3/8 flat washers (9). Bolt the footmount with pump to the engine bracket (1) with three 3/8 x 1 1/4 bolts (8), three 3/8 flat washers (9), and three 3/8 lock washers (10). Hold the harness bracket (4) in place over the top rear hole of the footmount (Location E) and attach it with the remaining 3/8 x 1 1/4 bolt, flat and lock washers.
10. Attach coil (3a) with four 1/4 x 1/2 flange bolts supplied with clutch. Torque these to 6 ft-lb. Attach clutch pulley (3b) to pump shaft with 5/16NF x 1 1/4 bolt and heavy washer supplied with clutch. Torque to 14 ft-lb.
11. Mount the DewEze tensioner (14) to the engine bracket at Location D using the 3/8 x 2 1/2 socket head bolt (16).
12. Mount the bracket to the engine using the M10 x 90 bolt (11) at Location A, and the M10 x 95 bolt (12) at Location B (torque both to 25 lb-ft). Replace the OEM bolt back at Location C fastening down the rear leg of the bracket.
13. Attach the wiring harness and heater hose line to the harness bracket (4) at Location F with the 5/16 x 3/4 bolt (23) and 5/16 nut (24) as shown in Fig. 4.
14. Install the belt (22) as shown in the diagram (Fig. 1).
15. Replace the radiator support rod. Replace the coolant in the radiator. Connect the battery cable.
16. Run the engine and check for any clearance or alignment problems. Adjust as needed.